

500 - 7,500 Litre Plastic Water Tanks

Tank Installation Instructions Warranty Terms and Conditions Tank Lifting



Please read these guidelines before installation.

Failure to prepare and install your tank correctly will void your warranty.



by **alixis**

Installation and use instructions for a 500 - 7,500 litre tank

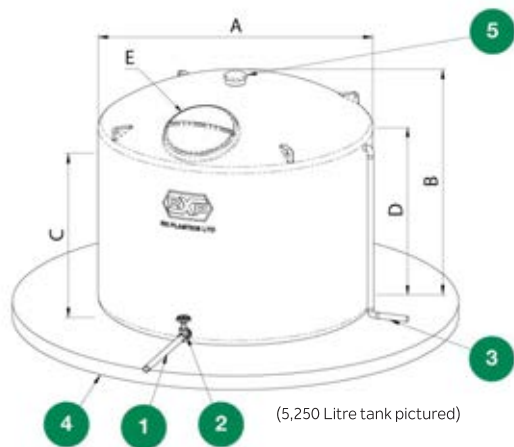

Notes:-

1. Flexible hose
2. Outlet supported
3. Overflow must be piped well away from tank foundation
4. Foundation - 100mm compacted sand or concrete pad
5. Vent in dome (recommended position)

Volume	A (Tank ϕ)	B (Tank H)	C (Lid H)	D (Wall H)	E (Lid ϕ)
500L	840	1190	1190	1000	450
1,100L	1200	1310	1310	1050	450
2,000L	1490	1430	1320	1215	450
3,200L	1860	1560	1335	1240	450
5,250L	2140	1860	1600	1505	450
7,500L	2510	1900	1600	1505	450

Advise RX Plastics immediately of transport damage prior to siting and installing your tank;

- It is the responsibility of the purchaser to ensure the tank is installed correctly using the guidelines supplied by RX Plastics and best plumbing practice.
 - Select a site that is flat and level.
 - The foundation (4) can be made from concrete; sand; crusher dust or compact native soil, measuring approximately 100mm deep and 600mm wider than the tank base. All bases (except concrete) must be supported to prevent erosion from wind, water and any other factor.
 - On sloping ground, ensure actual tank site and surrounding area are level and that the area will remain free from any possible erosion damage in the future.
 - RX Plastics DO NOT recommend that any RX Plastics tank is buried.
 - Immediately after delivery, secure the Tank by either tying down with rope (avoid over tightening) or partially filling with water, approximately 300mm deep.
- NOTE: - DO NOT attempt to lift a tank containing water - it must be completely drained before moving.

- RX Plastics require an overflow to be fitted. Ensure that the overflow does not erode the foundation.
- Overflow can be fitted in one of the panels beside the manhole (3). Minimum recommended overflow size is 90mm (subject to inlet size).
- Ensure all pipe work from the tank is supported to reduce stress on the tank. Use flexible pipe (1) or bellows on all pipe work to allow the tank to expand and contract (up to 50mm). NOTE - PE pipe is not considered flexible.
- To avoid the possibility of internal pressure; vacuum or heat build-up (when empty or full), a vent (5) must be installed. A recommended vent of 100mm is required for AS/NZS 4766 compliant tanks. Always seek advice from tank manufacturer before installing.
- Any tank with an outlet (2) that is over 50mm BSP is not compliant to AS/NZS4766.
- Any tank with an outlet (2) exceeding 100mm in the lower section of the tank wall will NOT be covered by the RX Plastics warranty.
- Cleaning of tanks is advised if used for potable water supply. Seek advice from specialist tank cleaning company.
- Ensure any fittings that may be screwed into the tank are not cross threaded and are not overtightened to avoid leaking.
- No unauthorised repairs, modifications or alterations should be undertaken without prior written approval from RX Plastics as this will void the warranty.
- RX Plastics do not recommend entering the tank for any reason, but if required follow MBIE guidelines on confined spaces entry before and during the procedure.
- Heavy, unsupported loads are not permitted on the tank dome or wall - this includes standing on the dome under any circumstances or unsupported pipework

NOTE: To view the TANK WARRANTY conditions go to the RX Plastics website - www.rxplastics.co.nz/max-and-metro-water-tanks

TANK LIFTING

Issue: 4 July 2018

RX Plastics recommends the following for normal situations where a tank is required to be lifted into position using the moulded in lifting lugs.

- All lifting lugs to be used to perform this task
- Tank must be empty of all contents
- The use of spreader bars to be used on all lifting lugs
- Long chains or strops to be used to lift tank

RX Plastics recommends the use of compliant lifting equipment to Work Safe New Zealand guidelines.

These recommendations are for ground based lifting and do not include aerial transportation.



RX Plastics 500-30,000 Litre Plastic Water Tank - Any tank colour

20 Year Product Warranty

The warranty for this product will be for a period of twenty (20) years from the date of purchase. (Proof of purchase and proof of date of purchase may be required).

Warranty for the tank will provide coverage from freedom from defects, faulty workmanship or materials. (Please read the following instructions carefully):

This **WARRANTY** is **VOID** under the following conditions:

- In the event that the tank and fittings are not installed strictly in accordance with the Tank Site Preparation guidelines
- If used for any purpose than as a stationary water tank.
- Unauthorised repairs, modifications, alterations or relocation without prior written approval from RX Plastics.
- Act of God.
- If the defect arises from use that is other than fair wear and tear.
- That the tank has not been adequately vented to prevent vacuum or pressurisation of vessel. Refer to Tank Manufacturer for advice.
- Damage sustained while in transit or on the Merchants premises.
- The warranty does not cover consequential loss or damage howsoever arising.
- The warranty does not cover minor cosmetic damage or slight variations in tank colour.
- The warranty does not cover leaking of factory fitted fittings or mechanical fittings, unless they arise from defects of the fittings, or faulty materials.
- Prompt notification shall be give to RX Plastics of any defect or failure. RX Plastics agrees to either repair or replace as its option under terms of this warranty.